

# Introduction to Decision Analysis

Presentation to  
NCAR WAS\*IS Workshop 1  
Boulder, CO  
November 10, 2005  
Jennie Spelman Rice

# When to Use Decision Analysis?

## **When decisions are made difficult by:**

- **Uncertainty:** e.g., meteorological phenomena; cost, effectiveness, and lead time of alternatives
- **Complexity:** e.g., many variables, alternatives, regulations, institutional/organizational levels, political, and social issues
- **Risk:** e.g., potential for loss of life, large financial/property impacts, large environmental impacts, etc.
- **Tradeoffs:** e.g., minimizing ratepayer costs vs. environmental damage

***Decision analysis is a proven methodology to address these issues.***

# The Decision Analysis Cycle

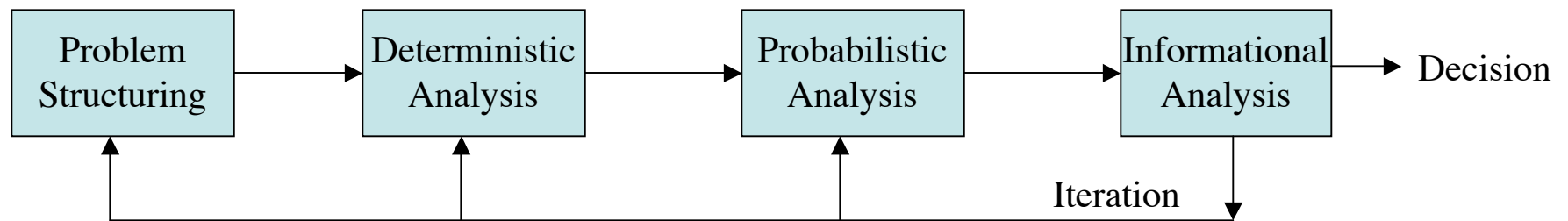

Clarify alternatives, information, values

Build mathematical model of the decision; Sensitivity analysis to identify key variables

Represent key variables with probability assessments; Determine best plan

Determine value of additional research and data gathering for each key variable

A simple example illustrates  
the DA cycle

# Orange Grower's Decision Problem

- Frost could occur overnight
- Frost protection costs money
- Total crop loss if frost occurs without protection measures in place

# Problem Structuring

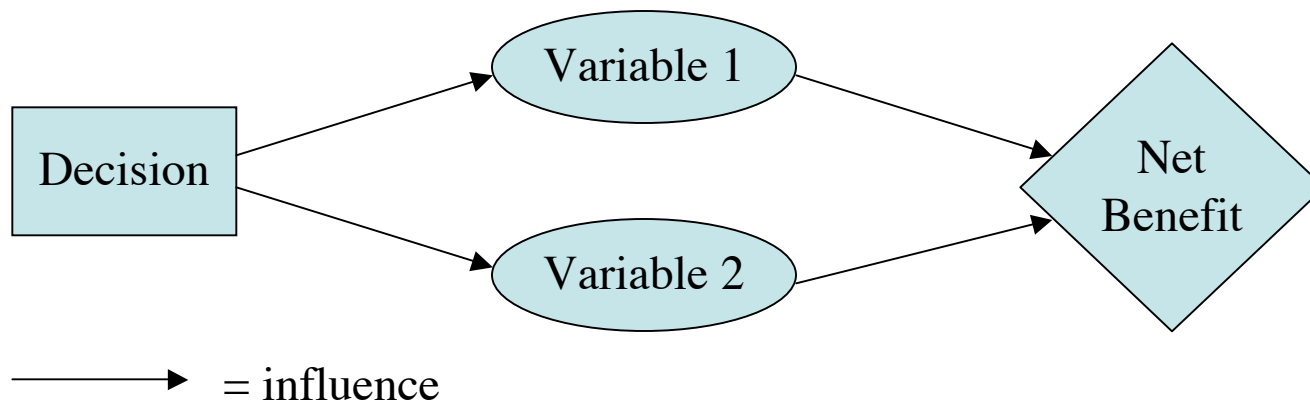

1. Clarify and distinguish between decisions and outcomes, values and information.
2. Involve all parties to the decision by including their perspectives.
3. Create a graphical representation of the decision, usually an influence diagram or decision tree.



# Problem Structuring

## --Using Influence Diagrams--

Influence diagrams describe the relationships between decisions, uncertainties, and final outcomes

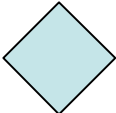
- Rectangles show decisions 
- Arrows show the direction of influence 
- Ovals show uncertainties 
- A diamond shows the net impact 

# Problem Structuring

## --Influence Diagram--

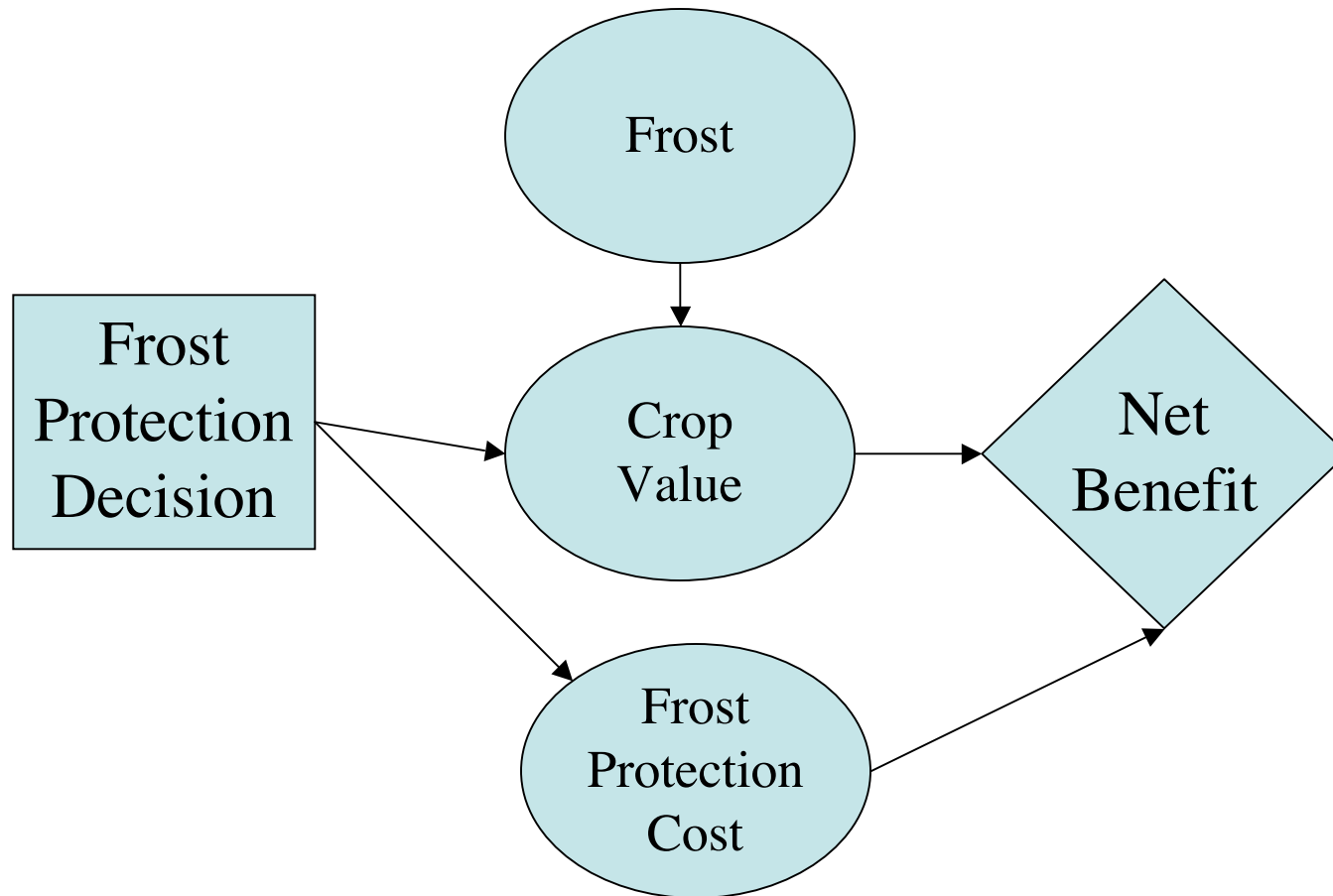

# Problem Structuring

--Value Model--

Net Benefit of Frost Protection Decision =

Crop Value - Frost Protection Cost

# Problem Structuring

## --Data and Information--

- Frost protection cost = 25
- Value of undamaged crop = 100
- Value of crop if frost occurs, but with frost protection = 75
- Value of crop if frost occurs, no frost protection = 0

# Deterministic Analysis

1. Develop a mathematical model that can evaluate the alternatives using the value model.
2. Develop base case and low and high values for each input variable reflecting the range of uncertainty (e.g., 90% confidence interval values).
3. Determine the preferred alternative with the base case values.
4. Identify “sensitive” variables, that is, those whose low or high values can change the preferred alternative.

# Deterministic Analysis

## --Sensitivity Analysis--

Net Benefit	Frost	No Frost
Frost Protection	50	75
No Frost Protection	0	100

The frost uncertainty changes the decision: it is a sensitive variable and should be modeled probabilistically

# Probabilistic Analysis

1. Develop probability assessments for sensitive variables.
2. Integrate deterministic model with a decision tree model.
3. Calculate expected value and/or risk-adjusted value of each alternative.

# Probabilistic Analysis

## --Probability Assessment--

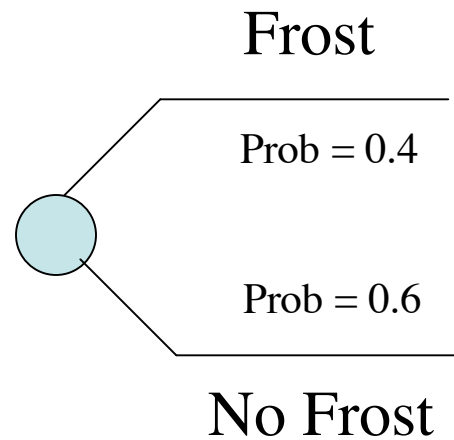

# Probabilistic Analysis

--Decision Tree--

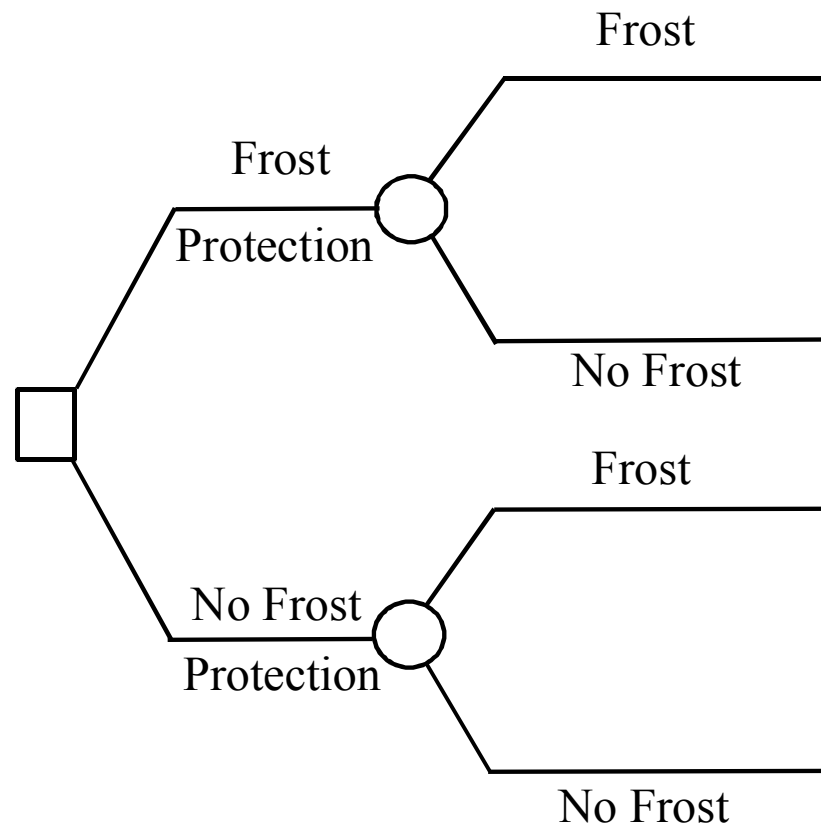

# Probabilistic Analysis

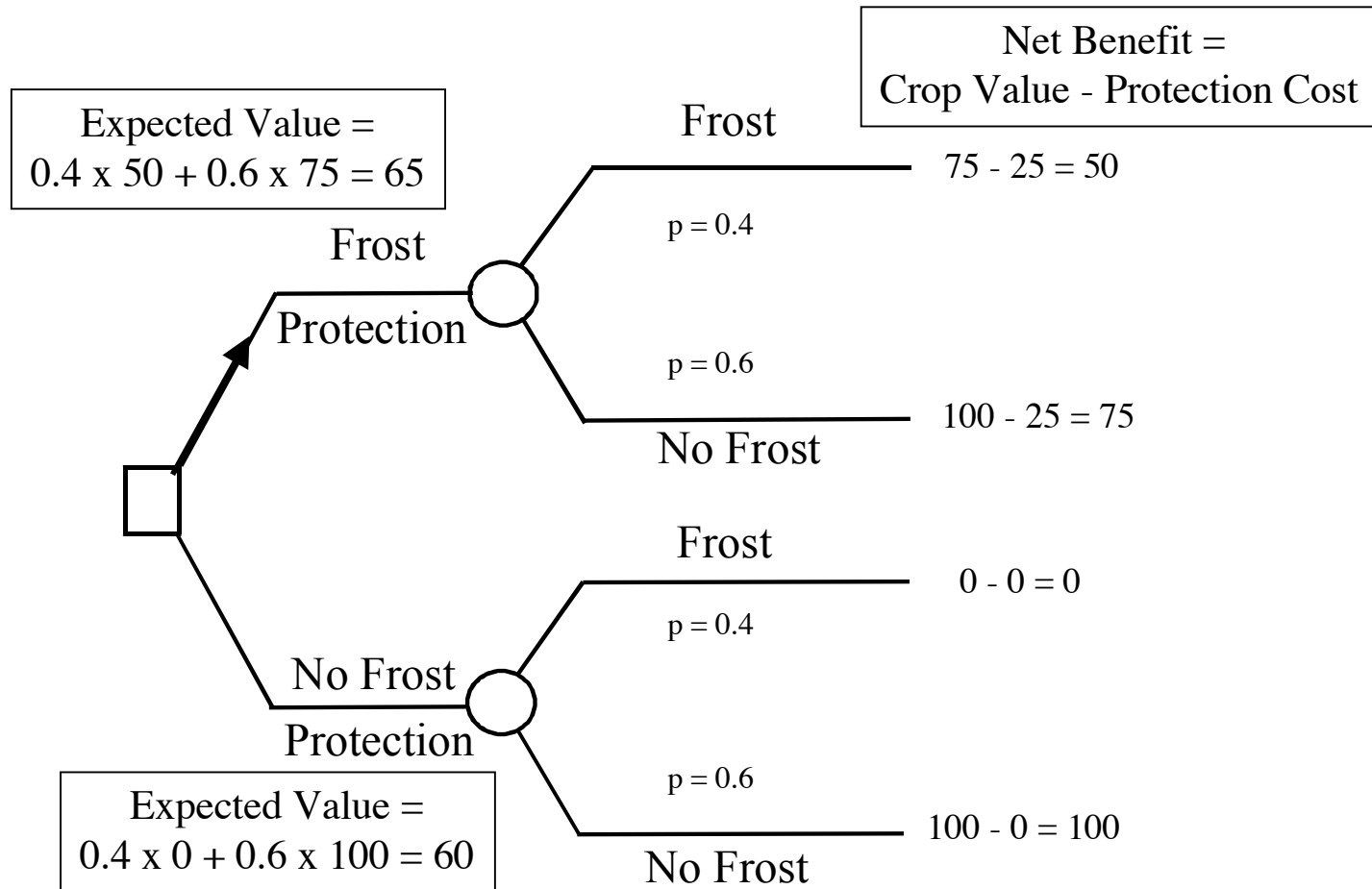

# Informational Analysis

1. Calculate value of perfect information.
2. Calculate value of imperfect information.
3. Calculate value of control.
4. Decide whether to gather additional information and iterate through the cycle.

# Informational Analysis

## --Value of Perfect Information--

- The value of perfect information (VOPI) on a variable is calculated as:
  - Expected Value With Perfect Information
  - Expected Value Without Perfect Information
- VOPI is an upper bound on the value of additional research to improve the probability assessment on an uncertain variable.
- In a more complicated problem, the variables can be ranked according to VOPI, providing guidance for additional research.

# Value of Perfect Information

## --Influence Diagram--

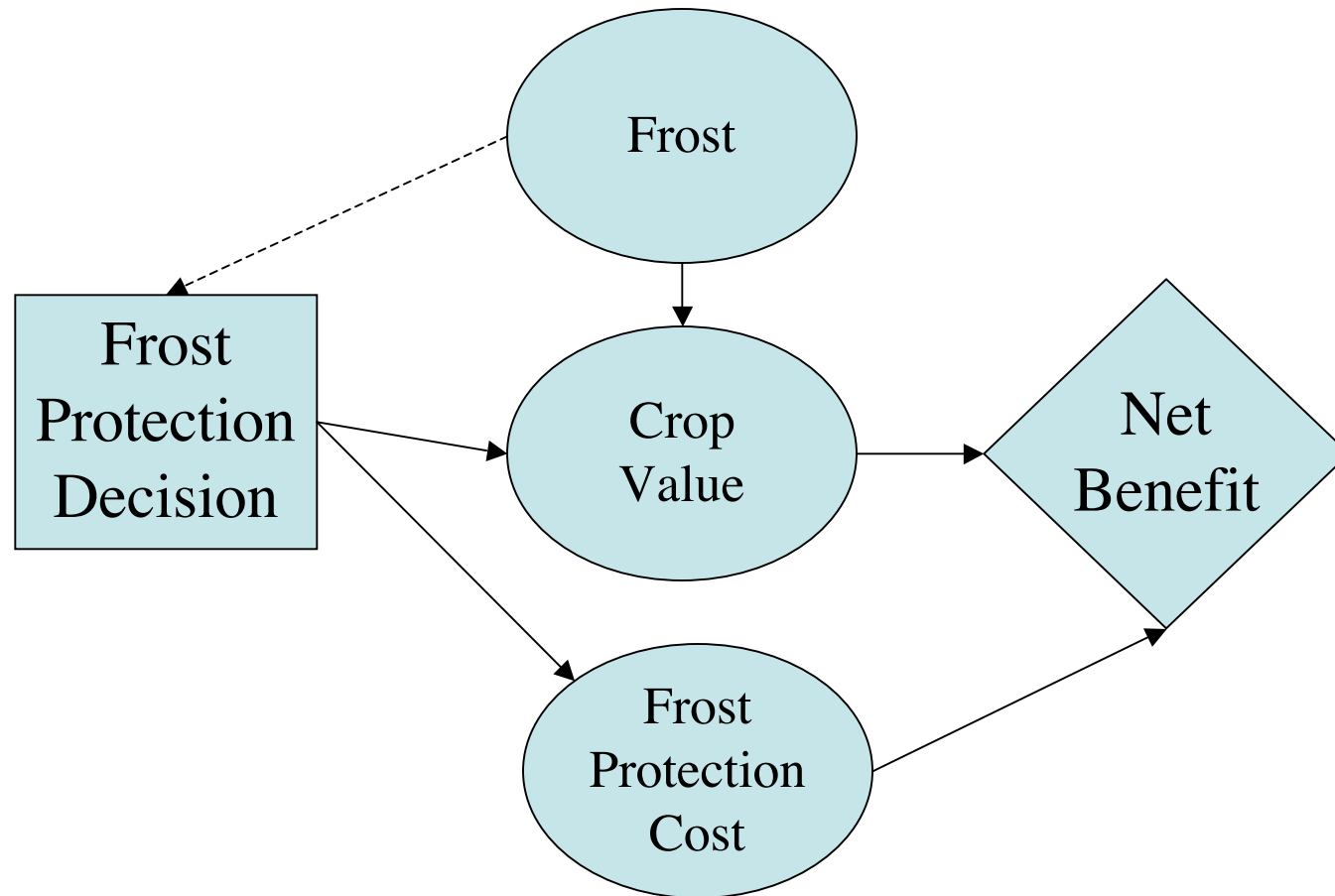

# Value of Perfect Information

## --Decision Tree--

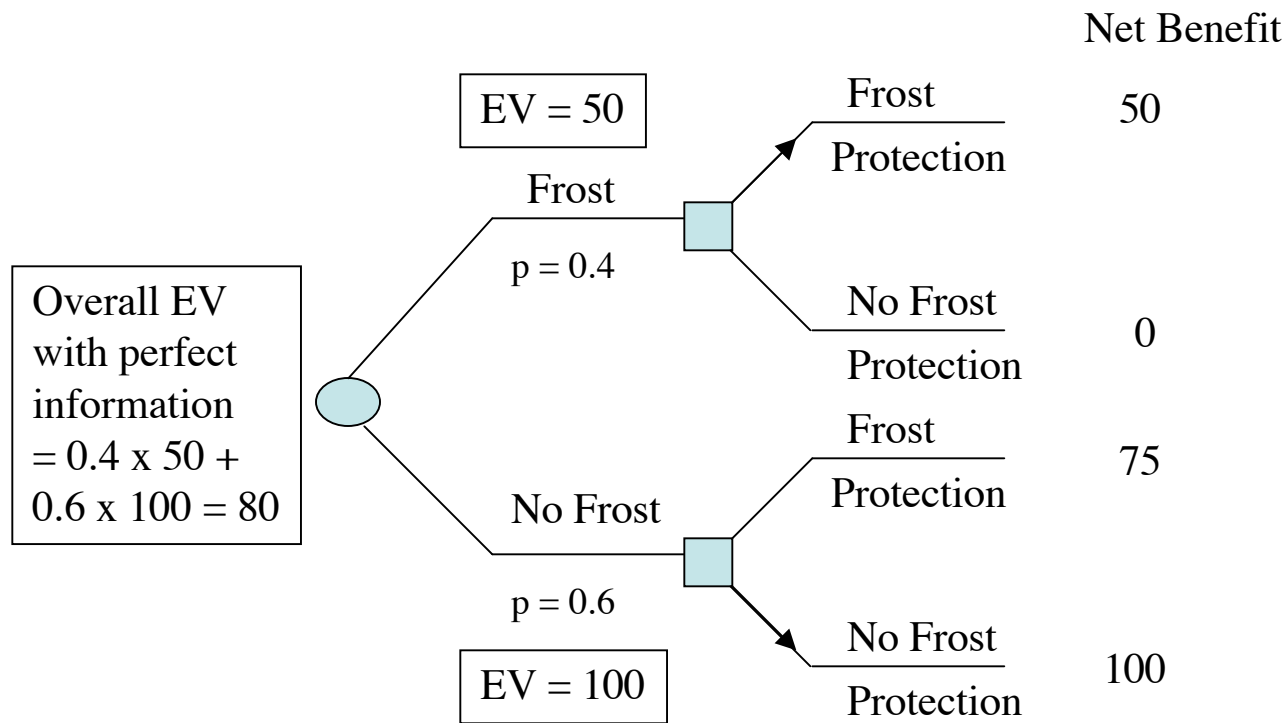

So,  $VOPI = 80 - 65 = 15$

# Informational Analysis

## --Value of Imperfect Information--

- The value of imperfect information (e.g., a frost forecast) can also be determined with decision analysis.
- This is a more complex calculation and requires the use of Bayesian updating.

# Value of Imperfect Information

- Is it worth paying for a frost forecast with an accuracy of 80%?

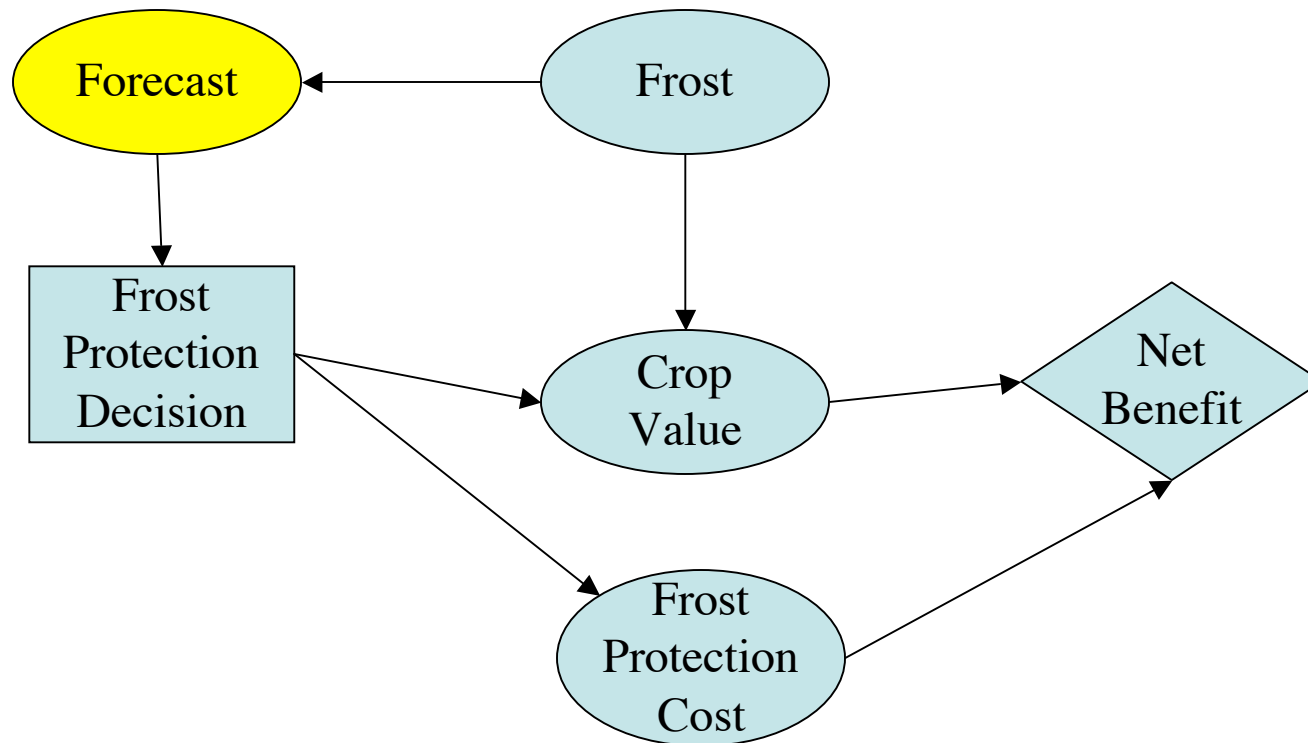

# Applying Bayes' Rule

“Nature’s Probability Tree”

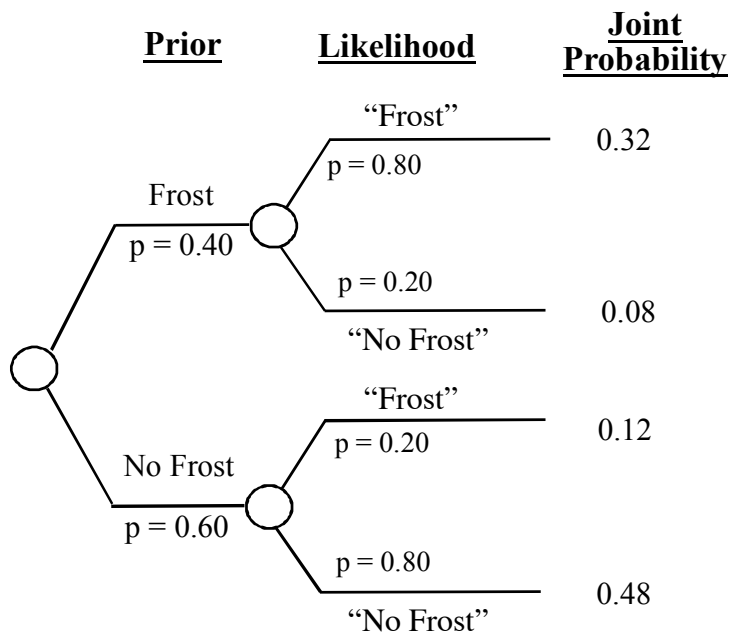

“Decision Maker’s Probability Tree”

Bayes' Rule  
→

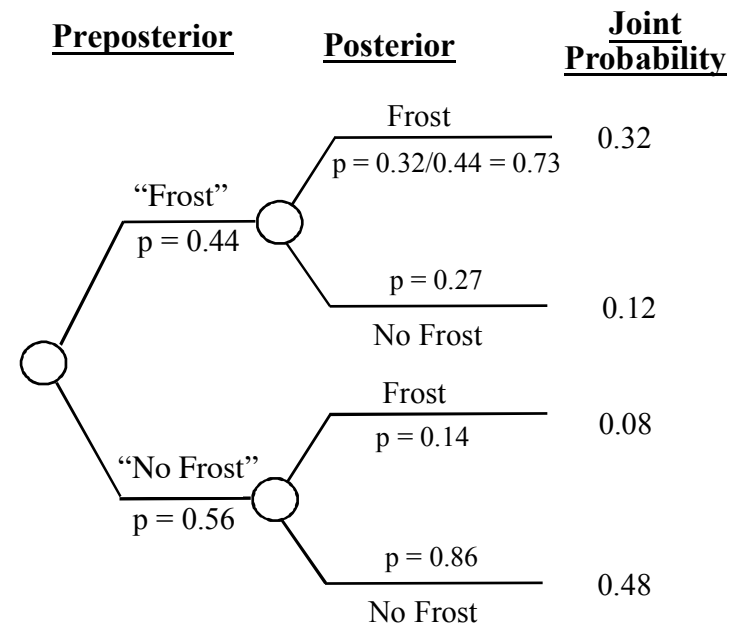

# Value of Imperfect Information

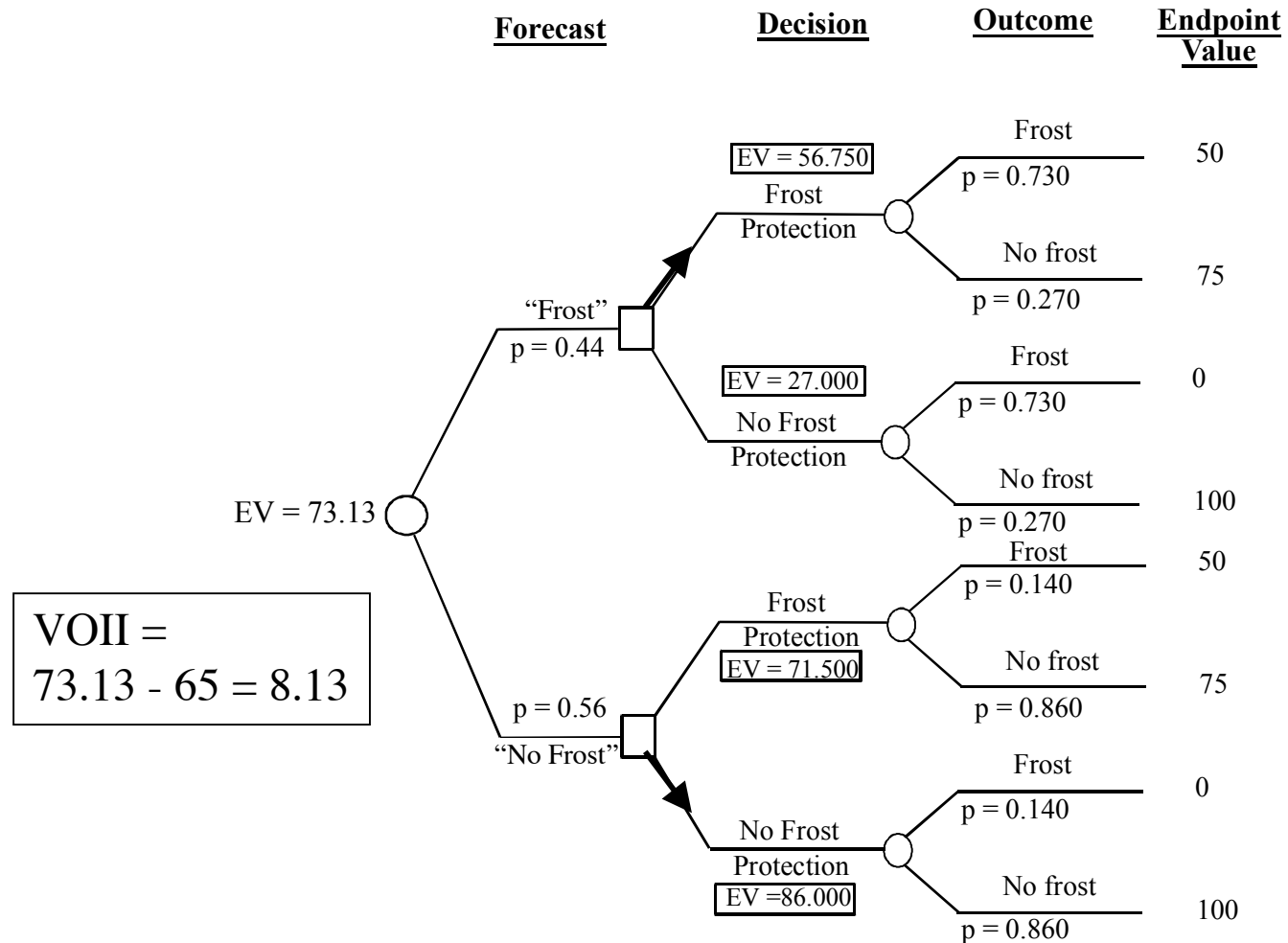

# Informational Analysis

## --Value of Control--

- The value of control determines the upper bound on the value of controlling an uncertainty (e.g., frost).
- Value of Control = Expected Value With Control - Expected Value Without Control
- This value can be used to gauge the cost-effectiveness of new alternatives (e.g., greenhouses).

# Informational Analysis

## --Value of Control--

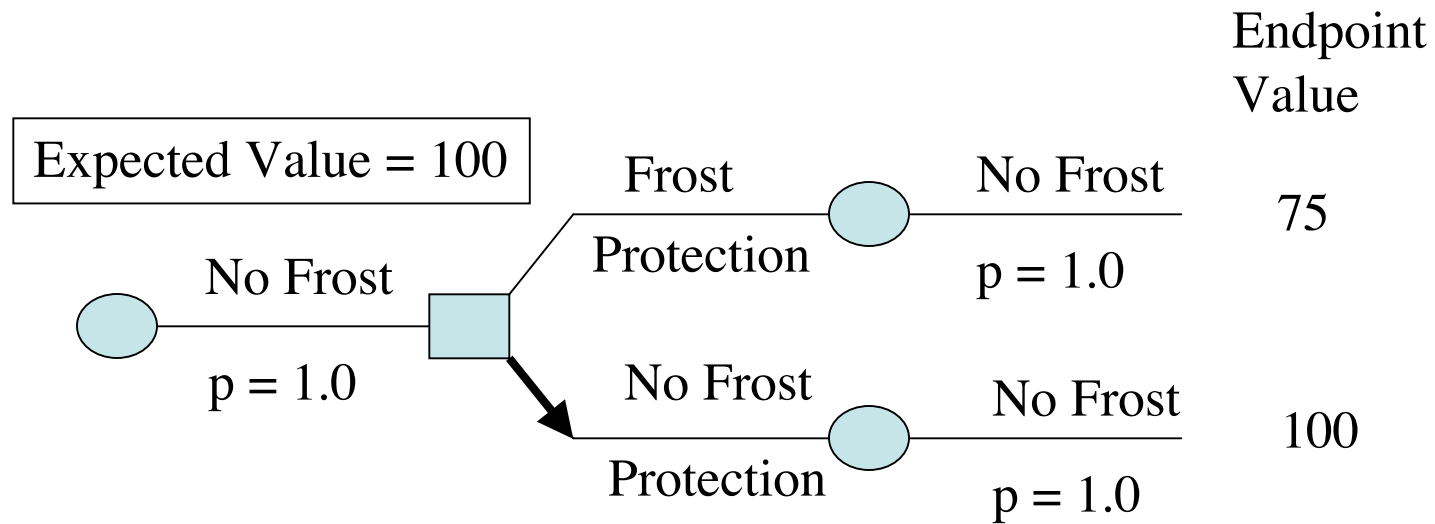

$$\text{Value of Control} = 100 - 65 = 35$$

# Potential Weather-Related DA Applications

- Value of new or improved warning systems (e.g., louder tornado sirens, earlier notification due to better data collection)
- Value of improved forecasts/better modeling (i.e., what meteorological data are most worth chasing?)
- Value of improved public response capability (e.g., police, transportation, health vis a vis flooding)
- Value of infrastructure improvements (e.g., building codes, levy construction, sea walls, etc.)

# Benefits of Decision Analysis

- *Incorporates Uncertainty.* Mathematically incorporates uncertain events and efficiently guides data gathering.
- *Handles Complexity.* Integrates multiple perspectives and provides a structured approach to include the breadth of the situation, yet focuses the analysis on the most important factors.
- *Addresses Value Tradeoffs and Risk.* Quantifies attitudes toward risk as well as multiple objectives to evaluate alternatives.
- *Provides Consistency.* Implementation in a systematic fashion reduces dependence on key individuals, avoids hunches/ego, and encodes embedded knowledge.
- *Creates Insight.* Value of information/control calculations create insights to make better decisions about future research and data gathering efforts.

Jennie Spelman Rice  
240 Dixon Road  
Boulder, CO 80302  
[jenniesrice@yahoo.com](mailto:jenniesrice@yahoo.com)  
303-444-2207